

**NARRATIVE:**

THE PURPOSE OF THIS SURVEY IS TO MONUMENT AND REFERENCE GENERAL LAND OFFICE CORNERS WHICH LIE IN TOWNSHIP 4 NORTH, RANGE 27 EAST, WITHIN UMATILLA COUNTY, UNDER A CONTRACT WITH UMATILLA COUNTY DATED JULY 2002.

THE SOUTH LINE OF THIS TOWNSHIP WAS FIRST SURVEYED BY HAFT IN 1860 UNDER CONTRACT #91. GOULD DID A DEPENDENT RESURVEY IN 1940 IN T 3 N, R 27 E, AND SET BRASS CAP MONUMENTS ALONG THIS LINE. THE EAST LINE OF THIS TOWNSHIP WAS FIRST SURVEYED IN 1860 BY HAFT UNDER CONTRACT #93. IT WAS RESURVEYED IN 1874 BY WALDEN UNDER CONTRACT 209. IT WAS ALSO SURVEYED BY GOULD IN A 1941 DEPENDENT RESURVEY WHERE HE SET BRASS CAP MONUMENTS. THE NORTH LINE OF THIS TOWNSHIP WAS SURVEYED IN 1860 BY MAXON AND HURD AND ALSO WAS SURVEYED BY GOULD IN HIS DEPENDENT RESURVEY IN WHICH HE SET BRASS CAPS AT THE STANDARD CORNERS. THE WEST LINE OF THIS TOWNSHIP WAS FIRST SURVEYED BY HAFT IN 1860 UNDER CONTRACT #93. THEN BY DAVID IN 1870 UNDER CONTRACT # 131, THEN BY WALDEN IN 1874 UNDER CONTRACT # 209, AND THEN IN A DEPENDENT SURVEY BY GOULD IN 1939 IN WHICH HE SET BRASS CAP MONUMENTS. THE INTERIOR WAS SURVEYED BY WALDEN IN 1874 UNDER CONTRACT # 209. IN ALL OF THE PRE 1939 SURVEYS THE MONUMENTS SET WERE POSTS IN MOUNDS SOMETIMES WITH PITS AND CHARCOAL.

THE INITIAL CONTROL USED FOR THIS SURVEY WAS NGS HIGH PRECISION GEODETIC CONTROL NETWORK POINT STANFIELD EAST BASE RESET RB 1421 AND THE SELECTED GEODETIC CONTROL SURVEY NETWORK PERFORMED BY EAGLE GPS SURVEY CORPORATION IN 1993; MEASUREMENTS WERE OBSERVED FROM THESE POINTS TWO SEPARATE TIMES TO THE CORNERS LOCATED WITHIN THE TOWNSHIP. A LEAST SQUARES ADJUSTMENT WAS THEN PERFORMED TO ESTABLISH STATE PLANE COORDINATES ON THE MONUMENTS RECOVERED UTILIZING RTK METHODS WITH FIXED SOLUTIONS ONLY. THE MONUMENTS RECOVERED WERE MEASURED TWO TIMES FROM THE CONTROL POINTS AND VECTOR FILES WERE CREATED TO ACCOMPLISH A LEAST SQUARES ADJUSTMENT ON THESE MONUMENTS.

PRIMM LAND SURVEYING/EDWARDS SURVEYING ELECTED TO COMBINE THIS PROJECT INTO ONE FILE BASED ON THE MINIMUM NUMBER OF CORNERS. THE FINAL ADJUSTED COORDINATES ARE NAD 83/91 OREGON STATE PLANE COORDINATES NORTH ZONE. INTERNATIONAL FEET, METERS, AND LATITUDE/LONGITUDE ARE INCLUDED.

THIS SURVEY WAS ACCOMPLISHED UTILIZING THE TOPCON LEGACY H, SOKKIA SET 300, TOPCON GTS 38, AND THE HYPER SYSTEM.

THE BEARINGS SHOWN ON THIS MAP ARE TRUE. SURVEYS DONE IN SECTIONS 27, 28, AND 29 FOUND NORTH-SOUTH FENCE LINES RUNNING NORTHWEST AND MISSING SECTION CORNERS THAT WERE MOSTLY PROPORTION IN BY SURVEYORS IN THE 50'S AND 60'S. I (EDWARDS) HAD ALWAYS ASSUMED THAT THE FENCE CORNERS ALONG THE NORTH LINE OF THESE SECTIONS WERE PROBABLY A BETTER REPRESENTATION OF THE SECTION CORNERS THAN THE SURVEYED CORNERS. BUT, AFTER ANALYZING THIS SURVEY WE HAVE CONCLUDED THAT THE NORTH SURVEYED CORNERS OF THOSE THREE SECTIONS ARE THE BEST LOCATIONS. THE PROBLEM IS WITH THE SOUTH SECTION CORNERS OF THOSE THREE SECTIONS. WHEN MONUMENTS WERE ESTABLISHED BY SURVEYORS AROUND THE 1950'S THEY WERE SET QUITE A DISTANCE WEST OF THEIR ORIGINAL LOCATIONS (SEE ON THE MAP WHERE THEY LIE IN RELATION TO THEIR PROPORTIONAL LOCATIONS). PEOPLE WHO ESTABLISHED FENCES AND ROADS RUNNING NORTH OF THOSE CORNERS PROJECTED THE INCORRECT SECTION LINES TO THE NORTH AND COMPOUNDED THE ERROR. THOSE LINES WERE RUNNING NORTHWEST INSTEAD OF NORTH.

WE ARE LEAVING ALL OF THE MONUMENTS AS SURVEYED BECAUSE SO MANY SURVEYS HAVE BEEN DONE USING THEM. THE PROPORTIONAL LOCATION OF THE SOUTH CORNERS OF THOSE THREE SECTIONS ARE SHOWN AS (P) ON THE MAP.

<p>REGISTERED PROFESSIONAL LAND SURVEYOR</p> <p><i>Brit L. Primm</i></p> <p>OREGON JULY 13, 1999 BRIT L. PRIMM 48509</p> <p>EXPIRATION DATE: 12/31/04</p>	<p>REGISTERED PROFESSIONAL LAND SURVEYOR</p> <p><i>G. Dennis Edwards</i></p> <p>OREGON JULY 16, 1971 G. DENNIS EDWARDS 915</p> <p>RENEWS 12/31/2003</p>
---	---

- LEGEND:**
- MONUMENTS FOUND AS NOTED OR:
    - (G) FOUND 2 1/2" BRASS CAP, GOULD 1939 DEPENDENT RE-SURVEY T 4 N, R 26 E
    - (G) FOUND 2 1/2" BRASS CAP, GOULD 1940 DEPENDENT RE-SURVEY T 3 N, R 27 E
    - (G) FOUND 2 1/2" BRASS CAP, GOULD 1941 DEPENDENT RE-SURVEY, OR SET FROM GOULD'S WITNESS CORNERS
    - (H) FOUND 2 1/2" BRASS CAP SET BY HARRIS IN 1966 SURVEY FOR UMATILLA COUNTY CS #C-20-B
    - SET 5/8"x30" IRON REBAR WITH PLASTIC CAP #951
    - COMPUTED LOCATION AS NOTED
    - (000) OF RECORD, FILED SURVEYS
    - S STAEBLER SURVEYS AS NOTED
    - K KRUMBEIN SURVEYS AS NOTED
  - [000] OF RECORD, G.L.O. CONTRACT #209
  - [000] OF RECORD, G.O. CONTRACT #209
  - (P) PROPORTIONAL EASTING LOCATION OF SEC. COR.

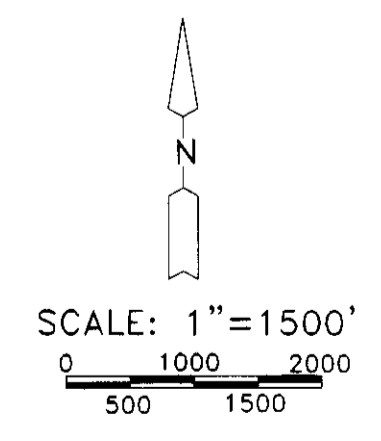

RECEIVED BY  
Umatilla County Surveyors  
Date: 4-01  
Rec'd by: KE  
03-54-C

SURVEY FOR UMATILLA COUNTY  
IN T 4 N R 27 E, W.M.,  
UMATILLA COUNTY, OREGON  
12/30/2002 JOB# T4N27E  
REV. 3/27/03

PRIMM LAND SURVEYING P.O. BOX 1322 541-564-7887 HERMISTON, OREGON 97838

EDWARDS SURVEYING P.O. BOX 763 541-567-3336 HERMISTON, OREGON 97838  
DRAWN BY NJF