

# RECORD OF SURVEY

## NARRATIVE

THIS SURVEY WAS MADE AT THE REQUEST OF JUDY SMYTHE OF UNIVERSAL REALTY. THE PURPOSE OF THE SURVEY WAS TO RECOVER OR REESTABLISH MONUMENTS FOR PARCEL 3 OF PARTITION PLAT NO. 1999-16 AND TO LOCATE THE HOUSE ON SAID PARCEL 3.

WE RECOVERED AND FLAGGED THE REBAR MONUMENTS DEFINING THE BOUNDARY OF PARCEL 3. WE NOTED A PORTION OF THE 8 FOOT GRAVEL DRIVEWAY TO THE HOUSE ON PARCEL 3 AND A FENCE IS LOCATED ACROSS A PORTION PARCEL 2 OF PARTITION PLAT NO. 1999-16. THE LOCATION OF THE FENCE AND DRIVE ACROSS PARCEL 2 IS SHOWN IN THE "DETAIL" ON THIS RECORD OF SURVEY. WE RECOMMEND AN INGRESS-EGRESS EASEMENT BE OBTAINED FROM THE OWNER OF PARCEL 2 TO COVER THE DRIVEWAY ENCROACHMENT.

WE ALSO NOTED THAT INGRESS-EGRESS TO PARCEL 3 FROM COUNTY ROAD NO. 983 IS ALONG AN EXISTING GRAVEL ROAD THAT PASSES ACROSS PARCELS 1 AND 2 OF PARTITION PLAT NO. 1999-16 BEFORE ENTERING PARCEL 3. A PORTION OF THIS GRAVEL ROAD IS KNOWN LOCALLY AS NE ELLIS PLACE AND HAS BEEN USED FOR MANY YEARS. NE ELLIS PLACE IS DESIGNATED ON COUNTY ROAD MAPS AS A PRIVATE ROAD. THIS ROAD PROVIDES ACCESS TO A NUMBER OF TRACTS OF LAND BETWEEN COUNTY ROAD NO. 983 AND NE 1ST STREET. WE RECOMMEND AN INGRESS-EGRESS EASEMENT BE OBTAINED FROM THE OWNERS OF PARCELS 1 AND 2 OF PARTITION PLAT NO. 1999-16 TO DOCUMENT ACCESS TO PARCEL 3.

THIS SURVEY WAS MADE BY A TWO PERSON CREW USING A LEICA TCR 803 THREE SECOND TOTAL STATION BY CLOSED TRAVERSE AND RADIAL TIES. CONTROL MONUMENT TIES AND MONUMENTS SET BY RADIAL METHODS WERE VERIFIED BY REDUNDANT OBSERVATIONS.

OWNER: HALLMAN W. EUGENE & MARY M.  
I.N. 1991-167281, DEED RECORDS.

NO.	BEARING	DISTANCE
L1	N 89°13'59" E	20.00'
	(N 89°13'59" E	20.00')
L2	S 00°46'01" E	30.00'
	(S 00°46'01" E	30.00')

SCALE: 1 INCH=40 FEET



UNIMPROVED PUBLIC ROAD  
REEL 78, PAGE 1355  
DEED RECORDS

UNIMPROVED PUBLIC ROAD  
REEL 78, PAGE 1355  
DEED RECORDS

OWNER: TERRACE PARK, INC.  
I.N. 1988-139136.

NOTE:  
THE BURIED UTILITIES SERVING THE HOUSE ON PARCEL 3 WERE NOT LOCATED.

PARCEL 3 OF PARTITION PLAT NO. 1999-16.  
ADDRESS:  
555 NE ELLIS PLACE  
PENDLETON, OREGON

OWNER: RENTON FELLER,  
I.N. 2011-5840698.  
PARCEL 2  
PARTITION PLAT  
1999-16

PARCEL 1  
PARTITION PLAT  
1999-16

OWNER: WELLS FARGO FINANCIAL OREGON, INC.,  
I.N. 2011-5760660

SEE DETAIL AT LEFT

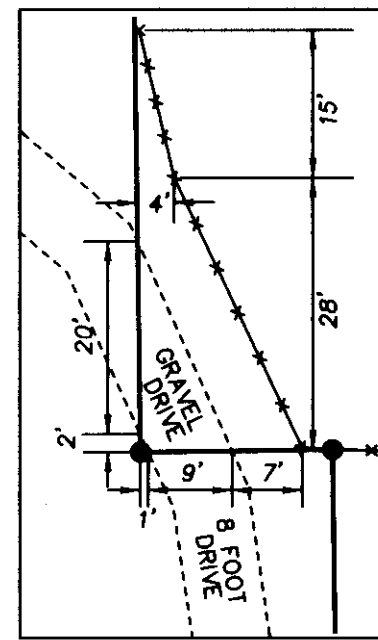

DETAIL  
SCALE: 1 INCH=20 FEET

OWNER: TERRACE PARK, INC.  
I.N. 1988-139136.

OWNER: EDMONDS, RALPH B., I.N.  
2009-5510617.

## LEGEND

- - FOUND 5/8" REBAR WITH 1 1/4" YELLOW PLASTIC CAP FROM PARTITION PLAT NO. 1999-16.
- ⊙ - FOUND 1/2" REBAR AS RECOVERED ON PARTITION PLAT NO. 1999-16.
- (XOX) - RECORD DIMENSION REPORTED ON PARTITION PLAT NO. 1999-16.
- L1 - LINE TOO SHORT TO ANNOTATE, SEE SHORT LINE TABLE.
- I.N. - INDICATES INSTRUMENT NUMBER IN UMATILLA COUNTY OFFICE OF RECORDS.
- - - - FENCE LINE.

NOTE:  
THE LEGAL DESCRIPTION FOR THE PROPERTY SURVEYED IS CONTAINED IN NOTICE OF DEFAULT AND ELECTION TO SELL, RECORDED AS INSTRUMENT NO. 2011-5790260, UMATILLA COUNTY OFFICE OF RECORDS.

## RECEIVED BY

Umatilla County Surveyor  
Date: 9/20/2012  
Rec'd By: S. Res  
No.: 12-132-B

REGISTERED PROFESSIONAL LAND SURVEYOR

*W. R. Wells*

OREGON  
JULY 22, 1977  
WILLIAM R. WELLS  
1106  
RENEWS 6/30/14

WELLS SURVEYING  
1 SW NYE AVENUE, SUITE B  
P.O. BOX 1696  
PENDLETON, OR 97801  
PHONE: (541) 276-6362

DATE: 09/12 DR. BY: WRW  
CK. BY: WRW NO: 12-1401

PROJECT: \UREALTY2012

BOUNDARY SURVEY FOR:  
UNIVERSAL REALTY

PARCEL 3 OF PARTITION PLAT NO. 1999-16,  
SITUATED IN THE SW1/4 OF  
SECTION 2, T2N., R32E., W.M.,  
CITY OF PENDLETON,  
UMATILLA COUNTY, OREGON.

COUNTY ROAD NO. 983, FORMERLY NO. 333  
(LEE STREET GRADE)

OWNER: PACIFIC POWER & LIGHT, BOOK 178, PAGE 295,  
DEED RECORDS.

EXISTING GRAVEL ROAD KNOWN AS NE ELLIS PLACE  
8 FOOT GRAVEL DRIVE TO ACCESS PARCEL 3

16 TO 18 FOOT GRAVEL ROAD USED TO ACCESS PARCEL 3 AND OTHER TRACTS AND PARCELS.

EXISTING GRAVEL ROAD KNOWN AS NE ELLIS PLACE

EXISTING GRAVEL ROAD

S 89°57'34" E 80.00'  
(S 89°57'34" E 80.00')

S 00°46'01" E 146.18'  
(S 00°46'01" E 146.18')

S 00°46'01" E 124.10'  
(S 00°46'01" E 124.10')

N 89°57'34" W 80.00'  
(N 89°57'34" W 80.00')

N 00°46'01" W 300.00'

N 00°46'01" W 26.9'

13.0'

8.0'

12.1'

50.1'

50.1'

26.9'

40.4'

108.9'

4.0'

1.5'

14.24' OF PARCEL 3 IS IN CONTACT W/ PUBLIC ROAD

N 00°46'01" W 300.00'

N 00°46'01" W 26.9'

13.0'

8.0'

12.1'

50.1'

50.1'

26.9'

40.4'

108.9'

4.0'

1.5'

N 89°57'34" W 80.00'  
(N 89°57'34" W 80.00')

FOUND 1/2" REBAR

OWNER: EDMONDS, RALPH B., I.N. 2009-5510617.

LEGEND

● - FOUND 5/8" REBAR WITH 1 1/4" YELLOW PLASTIC CAP FROM PARTITION PLAT NO. 1999-16.

⊙ - FOUND 1/2" REBAR AS RECOVERED ON PARTITION PLAT NO. 1999-16.

(XOX) - RECORD DIMENSION REPORTED ON PARTITION PLAT NO. 1999-16.

L1 - LINE TOO SHORT TO ANNOTATE, SEE SHORT LINE TABLE.

I.N. - INDICATES INSTRUMENT NUMBER IN UMATILLA COUNTY OFFICE OF RECORDS.

- - - - FENCE LINE.

- - - - FENCE LINE.