

LINE TABLE

#	BEARING & DISTANCE
L-1	N 0°02'10" E 11.90'
L-2	N 0°02'10" E 9.80'
L-3	N 0°04'10" E 9.80'
L-4	N 0°04'10" E 9.72'
L-5	N 0°02'11" E 197.02'

LEGEND:

- FOUND MONUMENTS AS NOTED
- SET 5/8"X30" IRON REBAR WITH PLASTIC CAP #951
- COMPUTED LOCATION
- (000) OF RECORD, MY 2/10 SURVEY FOR WEBB
- [000] OF RECORD, DEED
- {000} OF RECORD, PARTITION PLAT 2000-29
- DEED LINE

SURVEYOR'S NARRATIVE:

THE PURPOSE OF THIS SURVEY IS TO SURVEY ANNA HILL'S (R. 320, P. 436) AND MARK BARNARD'S (R. 182, P. 468) PARCELS TO SEE HOW THE FENCES LIE IN RELATION TO THE DEED LINES. THEN TO DO A BOUNDARY LINE ADJUSTMENT ON THE NORTH AND SOUTH LINES OF BARNARD'S TRACT.

I SUBDIVIDED THE NW 1/4 OF THE NE 1/4 BASED ON WAGNER'S SURVEY OF PARTITION PLAT 2000-29. THE BEARINGS ARE BASED ON MY FEB. 2010 SURVEY FOR WEBB IN THE NW 1/4 OF SECTION 21.

I USED A TOPCON HIPER+ G.P.S. TO CONDUCT THIS SURVEY.

REGISTERED
PROFESSIONAL
LAND SURVEYOR

G. Dennis Edwards

OREGON
JULY 16, 1971
G. DENNIS EDWARDS
9 5 1
RENEWS 12/31/2011

PARCEL 1
PARTITION PLAT 2000-29

PARCEL 2
PARTITION PLAT 2000-29

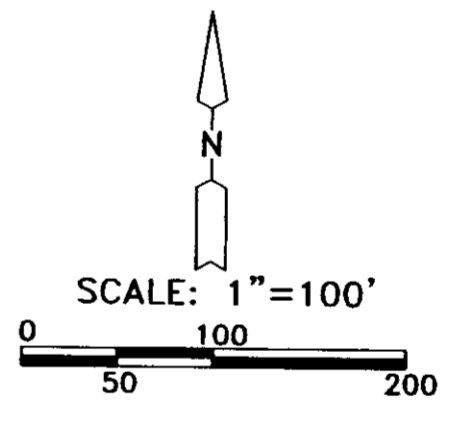

SURVEY FOR MARK BARNARD
IN NW 1/4, NE 1/4, SEC. 21, T 4 N,
R 28 E, W.M., UMATILLA COUNTY, OREGON
04/28/2010 JOB# S1004019
EDWARDS SURVEYING P.O. BOX 763
541-567-3336 HERMISTON, OREGON 97838
DRAWN BY JMC