

SEVEN LAKES REPLAT
 A REPLAT OF LOTS 1, 2, 3 AND 14, 15 AND 16,
 BLOCK 39, RESERVE ADDITION, PENDLETON, OREGON
 SITUATED IN THE SOUTHWEST QUARTER OF SECTION 10,
 TOWNSHIP 2 NORTH, RANGE 32 EAST, W.M.,
 CITY OF PENDLETON, UMATILLA COUNTY, OREGON.
 MAY, 2017

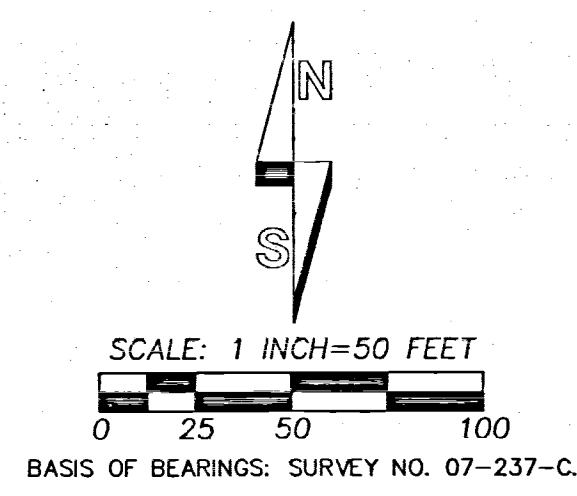

LINE TABLE

NO.	BEARING	DISTANCE
L1	N 65°10'04" E	30.01'
L2	S 23°35'57" E	66.71'
L3	S 66°24'17" W	35.00'
L4	N 21°24'35" E	42.42'
L5	S 65°10'04" W	30.01'

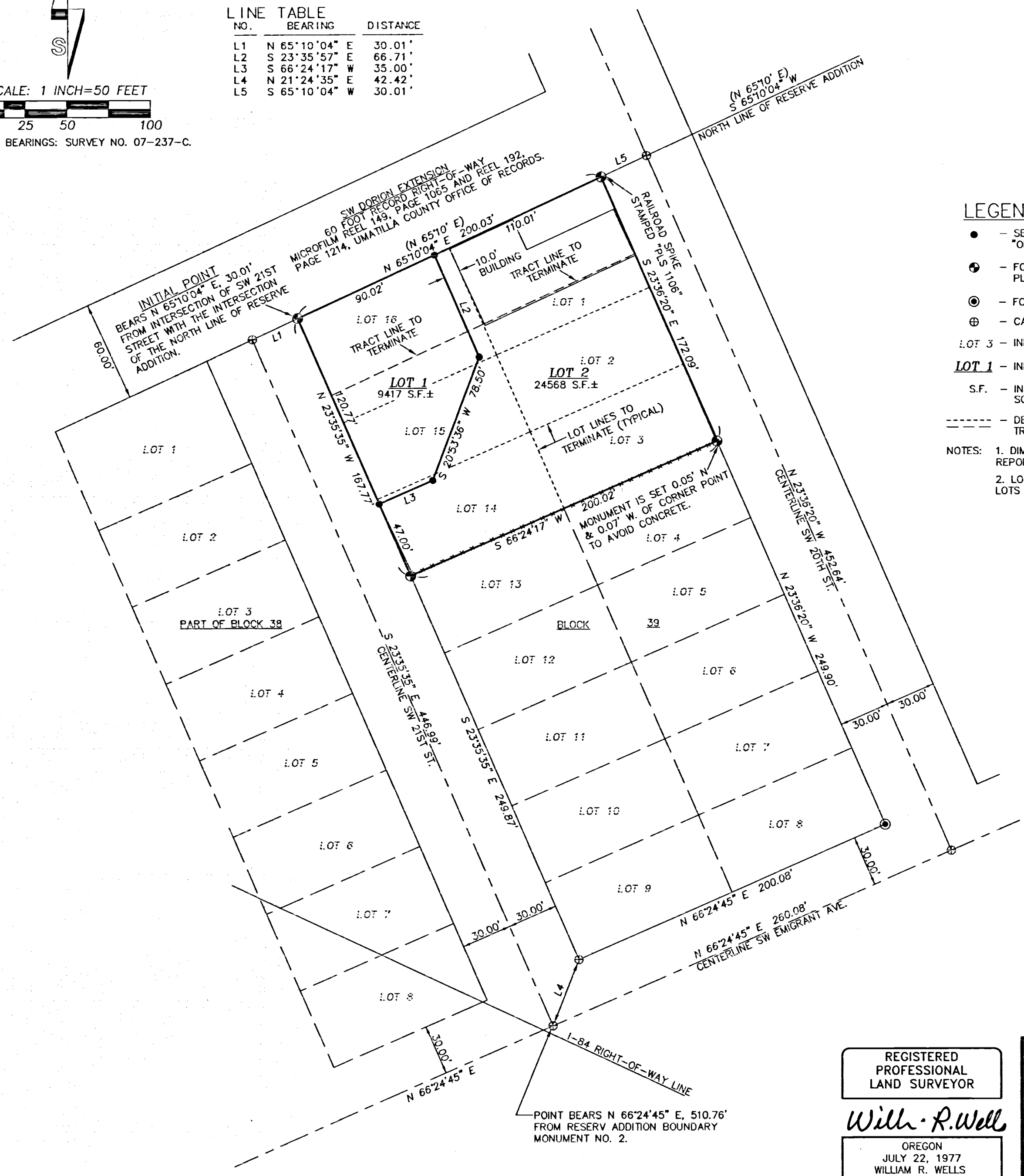

LEGEND

- - SET 5/8" BY 24" REBAR WITH 1 1/4" RED PLASTIC CAP MARKED "OR PLS 1106, WA PLS 17372", UNLESS OTHERWISE NOTED.
 - ⊕ - FOUND 5/8" REBAR WITH RED PLASTIC CAP MARKED "OR PLS 1106 WA PLS 17372" FROM SURVEY NO. 07-237-C UNLESS OTHERWISE NOTED.
 - ⊙ - FOUND RAILROAD SPIKE STAMPED "PLS 1106" FROM SURVEY NO. 02-284-B.
 - ⊕ - CALCULATED POINT ONLY, NOT SET OR FOUND.
 - LOT 3 - INDICATES EXISTING LOT NUMBER, RESERVE ADDITION.
 - LOT 1 - INDICATES NEW LOT NUMBER, PER THIS REPLAT.
 - S.F. - INDICATES SQUARE FEET. LOT AREAS ARE ROUNDED TO THE NEAREST SQUARE FOOT.
 - - DEPICTS LOT LINES FROM RESERVE ADDITION OR METES AND BOUNDS TRACT LINES, (TAX LOT LINES), TO TERMINATE BY THIS REPLAT.
- NOTES:
1. DIMENSIONS REPORTED ON THIS PLAT, WHICH ARE COMMON WITH THOSE REPORTED ON SURVEY NO. 07-237-C, ARE IDENTICAL.
 2. LOTS AND BLOCKS IN RESERVE ADDITION ARE COMMONLY REFERRED TO AS LOTS AND BLOCKS IN RESERVATION ADDITION IN VARIOUS DEEDS AND DESCRIPTIONS.

RECEIVED BY
 Umatilla County Surveyor
 Date: 11/30/17
 Rec'd By: CT
 No.: 17-130-B

RECORDING INFORMATION,
 UMATILLA COUNTY OFFICE OF RECORDS:

STATE OF OREGON, }
 COUNTY OF UMATILLA }

I certify that this instrument was received and recorded on 11-28-2017 at 8:56 o'clock a.m., in the record of PLATS of said County. BOOK 16 PAGE 56

OFFICE OF COUNTY RECORDS

By: David A Stuvland Records Officer
 Fee \$ 80.00 No. 2017-6650557

I CERTIFY THIS IS AN EXACT COPY OF SHEET 1 OF 2 OF SEVEN LAKES REPLAT.

William R. Wells
 WILLIAM R. WELLS, PLS

REGISTERED PROFESSIONAL LAND SURVEYOR

William R. Wells
 OREGON
 JULY 22, 1977
 WILLIAM R. WELLS
 1106
 RENEWS 6/30/18

WELLS SURVEYING
 200 SE HAILEY SUITE 108
 P.O. BOX 1696
 PENDLETON, OR 97801
 PHONE: (541) 276-6362

DATE: 05/17	DR. BY: WRW
CK. BY: WRW	NO: 16-1629

PROJECT: SEVEN LAKES REPLAT FINAL

SEVEN LAKES REPLAT
 A REPLAT OF LOTS 1, 2, 3 AND 14, 15 AND 16, BLOCK 39, RESERVE ADDITION, PENDLETON, OREGON

SITUATED IN THE SOUTHWEST QUARTER OF SECTION 10, TOWNSHIP 2 NORTH, RANGE 32 EAST, W.M., CITY OF PENDLETON, UMATILLA COUNTY, OREGON.

SURVEYOR'S CERTIFICATE

I, WILLIAM R. WELLS A PROFESSIONAL LAND SURVEYOR IN THE STATE OF OREGON, DO HEREBY CERTIFY THAT I HAVE CORRECTLY SURVEYED AND MARKED WITH LEGAL MONUMENTS, IN ACCORDANCE WITH ORS CHAPTER 92, AS REVISED, AND THE CITY OF PENDLETON AND UMATILLA COUNTY DEVELOPMENT ORDINANCES, THE LANDS SHOWN IN THE ACCOMPANYING "SEVEN LAKES REPLAT". THIS BASIS OF CONTROL FOR THIS REPLAT ARE THE MONUMENTS ESTABLISHED ON THIS REPLAT BOUNDARY ON SURVEY NO. 07-237-C.

REAL PROPERTY DESCRIPTION:

LOTS 1, 2, 3, AND 14, 15 AND 16, BLOCK 39, RESERVATION ADDITION, (PLATTED AS RESERVE ADDITION), RECORDED IN BOOK 1, PAGES 1 THROUGH 90, RECORD OF TOWN PLATS, UMATILLA COUNTY, OREGON. SITUATED IN THE SOUTHWEST QUARTER OF SECTION 10, TOWNSHIP 2 NORTH, RANGE 32 EAST, W.M., UMATILLA COUNTY, OREGON. SUBJECT TO EASEMENTS AND ENCUMBRANCES OF RECORD.

REGISTERED PROFESSIONAL LAND SURVEYOR

Will R. Wells
WILLIAM R. WELLS, PLS

Will R. Wells
OREGON
JULY 22, 1977
WILLIAM R. WELLS
1106
RENEWS 6/30/18

OWNER'S DECLARATION

GARY K. JELLUM, TRUSTEE OF THE GARY K. JELLUM REVOCABLE TRUST, AS TO AN UNDIVIDED ONE-SIXTH INTEREST IN "TRACT A" AND AMY K. JELLUM, TRUSTEE OF THE AMY K. JELLUM REVOCABLE TRUST, AS TO AN UNDIVIDED ONE-SIXTH INTEREST IN "TRACT A" AND MARY LOU FLETCHER, OR HER SUCCESSOR, SUCCESSOR TRUSTEE OF US BAR TRUST NO. 1, AS TO AN UNDIVIDED ONE-SIXTH INTEREST IN "TRACT A" AND MARY LOU FLETCHER, OR HER SUCCESSOR, TRUSTEE OF US BAR TRUST NO. 2, AS TO AN UNDIVIDED ONE-SIXTH INTEREST IN "TRACT A" AND JAMES L. WHITNEY, AS TO AN UNDIVIDED ONE-THIRD INTEREST IN "TRACT A" DO HEREBY ESTABLISH AND ACKNOWLEDGE THIS REPLAT AS THE OFFICIAL MAP AND PLAT OF "SEVEN LAKES REPLAT", PREPARED IN ACCORDANCE WITH ORS CHAPTER 92 AS REVISED AND THE CITY OF PENDLETON AND UMATILLA COUNTY DEVELOPMENT ORDINANCES.

GARY K. JELLUM, TRUSTEE
AMY K. JELLUM, TRUSTEE
MARY LOU FLETCHER, TRUSTEE
US BAR TRUST NO. 1
MARY LOU FLETCHER, TRUSTEE
US BAR TRUST NO. 2
JAMES L. WHITNEY

ACKNOWLEDGMENT

STATE OF OREGON) SS
COUNTY OF UMATILLA)
THIS INSTRUMENT WAS ACKNOWLEDGED BEFORE ME
THIS 26 DAY OF June 2017.
BY GARY K. JELLUM
Mary Earley
NOTARY PUBLIC FOR THE STATE OF OREGON
MY COMMISSION EXPIRES: February 19, 2018
COMMISSION NUMBER: 925323

ACKNOWLEDGMENT

STATE OF OREGON) SS
COUNTY OF UMATILLA)
THIS INSTRUMENT WAS ACKNOWLEDGED BEFORE ME
THIS 26 DAY OF June 2017.
BY AMY K. JELLUM
Mary Earley
NOTARY PUBLIC FOR THE STATE OF OREGON
MY COMMISSION EXPIRES: February 19, 2018
COMMISSION NUMBER: 925323

ACKNOWLEDGMENT

STATE OF OREGON) SS
COUNTY OF UMATILLA)
THIS INSTRUMENT WAS ACKNOWLEDGED BEFORE ME
THIS 26 DAY OF June 2017.
BY MARY LOU FLETCHER
TRUSTEE, US BAR TRUST NO. 1
Mary Earley
NOTARY PUBLIC FOR THE STATE OF OREGON
MY COMMISSION EXPIRES: February 19, 2018
COMMISSION NUMBER: 925323

ACKNOWLEDGMENT

STATE OF OREGON) SS
COUNTY OF UMATILLA)
THIS INSTRUMENT WAS ACKNOWLEDGED BEFORE ME
THIS 26 DAY OF June 2017.
BY MARY LOU FLETCHER
TRUSTEE, US BAR TRUST NO. 2
Mary Earley
NOTARY PUBLIC FOR THE STATE OF OREGON
MY COMMISSION EXPIRES: February 19, 2018
COMMISSION NUMBER: 925323

ACKNOWLEDGMENT

STATE OF OREGON) SS
COUNTY OF UMATILLA)
THIS INSTRUMENT WAS ACKNOWLEDGED BEFORE ME
THIS 26 DAY OF June 2017.
BY JAMES L. WHITNEY
Mary Earley
NOTARY PUBLIC FOR THE STATE OF OREGON
MY COMMISSION EXPIRES: February 19, 2018
COMMISSION NUMBER: 925323



SEVEN LAKES REPLAT
A REPLAT OF LOTS 1, 2, 3 AND 14, 14 AND 16,
BLOCK 39, RESERVE ADDITION, PENDLETON, OREGON.
SITUATED IN THE SOUTHWEST QUARTER OF SECTION 10,
TOWNSHIP 2 NORTH, RANGE 32 EAST, W.M.,
CITY OF PENDLETON, UMATILLA COUNTY, OREGON.
MAY, 2017

APPROVALS

CITY OF PENDLETON PLANNER

THE ACCOMPANYING REPLAT IS HEREBY APPROVED THIS
28TH DAY OF June 2017.

Joy Clark
PENDLETON CITY PLANNER

CITY OF PENDLETON SURVEYOR

THE ACCOMPANYING REPLAT IS HEREBY APPROVED THIS
28TH DAY OF June 2017.

David H. Klein
PENDLETON CITY SURVEYOR

UMATILLA COUNTY SURVEYOR

I CERTIFY I HAVE EXAMINED THE ACCOMPANYING PLAT, THAT IT COMPLIES WITH THE LAWS OF THE STATE OF OREGON, WITH REFERENCE TO THE FILING AND RECORDING OF SUCH PLATS, AND THEREFORE APPROVE SAID PLAT FOR SIGNATURE BY THE COUNTY COMMISSIONERS OF UMATILLA COUNTY, OREGON.

DATED THIS 29 DAY OF June 2017

David H. Klein
UMATILLA COUNTY SURVEYOR

UMATILLA COUNTY COMMISSIONERS

THE ACCOMPANYING REPLAT IS APPROVED FOR FILING AND RECORDING IN THE RECORD OF PLATS OF UMATILLA COUNTY BY THE UNDERSIGNED, BY ITS ORDER.

DATED THIS 6 DAY OF July 2017

William R. Wells
COMMISSIONER
William R. Wells
COMMISSIONER

UMATILLA COUNTY ASSESSOR & TAX COLLECTOR

WE, THE ASSESSOR AND THE TAX COLLECTOR OF UMATILLA COUNTY, OREGON, DO HEREBY CERTIFY THAT WE HAVE EXAMINED THE TAX RECORDS RELATIVE TO THE LAND COVERED BY THE ACCOMPANYING REPLAT AND THAT ALL AD/VALOREM AND SPECIAL ASSESSMENTS DUE PURSUANT TO LAW HAVE BEEN ASSESSED AND COLLECTED.

DATED THIS 28TH DAY OF November 2017.

Paul Chab
UMATILLA COUNTY ASSESSOR
Bettina Knight by
Kristen Shanard, deputy
UMATILLA COUNTY TAX COLLECTOR

RECORDING INFORMATION,
UMATILLA COUNTY OFFICE OF RECORDS:

STATE OF OREGON,
COUNTY OF UMATILLA }
I certify that this instrument was received
and recorded on 11-28-2017

at 8:56 o'clock a.m., in the record of
PLATS of said County,
BOOK 16 PAGE 56

OFFICE OF COUNTY RECORDS

By: David A. Stuvland Records Officer

Fee \$ 80.00 No. 2017-6650557

I CERTIFY THIS IS AN EXACT COPY OF
SHEET 2 OF 2 OF SEVEN LAKES REPLAT

Will R. Wells
WILLIAM R. WELLS, PLS

RECORD OWNERSHIP DESCRIPTIONS:

TRACT A

TRACTS DESCRIBED IN INSTRUMENT NUMBERS 2013-6130100, 2013-6130091 AND 2013-6130094, UMATILLA COUNTY OFFICE OF RECORDS), AND SPECIFICALLY DESCRIBED AS:

LOTS 15 AND 16, LESS THE NORTH 50 FEET OF SAID LOT 16, BLOCK 39, RESERVATION ADDITION (PLATTED AS RESERVE ADDITION), TO THE TOWN, NOW CITY OF PENDLETON, UMATILLA COUNTY, OREGON.

THE NORTH 50 FEET OF LOT 16, BLOCK 39, RESERVATION ADDITION (PLATTED AS RESERVE ADDITION), TO THE TOWN, NOW CITY OF PENDLETON, UMATILLA COUNTY, OREGON.

LOT 14, BLOCK 39, RESERVATION ADDITION (PLATTED AS RESERVE ADDITION), TO THE TOWN, NOW CITY OF PENDLETON, UMATILLA COUNTY, OREGON.

LOTS 1, 2 AND 3, BLOCK 39, RESERVATION ADDITION (PLATTED AS RESERVE ADDITION), TO THE TOWN, NOW CITY OF PENDLETON, UMATILLA COUNTY, OREGON. EXCEPTING THEREFROM, THAT TRACT OF LAND CONVEYED TO SEVEN LAKES DEVELOPMENT, LLC, DESCRIBED IN INSTRUMENT NO. 2007-5150627, UMATILLA COUNTY OFFICE OF RECORDS.

TRACT B

RECORD DESCRIPTION FROM INSTRUMENT NO. 2007-5150627, UMATILLA COUNTY OFFICE OF RECORDS:

BEGINNING AT THE NORTHEASTERLY CORNER OF LOT 1, BLOCK 39, RESERVATION ADDITION (PLATTED AS RESERVE ADDITION) TO THE TOWN, NOW CITY OF PENDLETON; THENCE SOUTH 65°10' WEST ALONG THE NORTHERLY LINE OF SAID LOT 1, A DISTANCE OF 100.02 FEET TO THE NORTHWESTERLY CORNER OF SAID LOT 1; THENCE SOUTH 23° 36' EAST ALONG THE WESTERLY LINE OF SAID LOT 1, A DISTANCE OF 50.00 FEET TO THE SOUTHWESTERLY CORNER OF THAT TRACT OF LAND CONVEYED TO VIRGIL O. FRYMIRE, ET UX, BY DEED RECORDED IN BOOK 265, PAGE 182, DEED RECORDS; THENCE NORTH 65°17' EAST A DISTANCE OF 100.11 FEET TO A POINT ON THE EASTERLY LINE OF SAID LOT 1, SAID POINT ALSO BEING THE NORTHEASTERLY CORNER OF THAT TRACT OF LAND CONVEYED TO F. J. THORNE, ET UX, BY DEED RECORDED IN BOOK 265, PAGE 183, DEED RECORDS; THENCE NORTH 23°36' WEST ALONG THE EASTERLY LINE OF SAID LOT 1, A DISTANCE OF 50.16 FEET TO THE POINT OF BEGINNING.

ALL BEING IN THE COUNTY OF UMATILLA AND STATE OF OREGON.

OWNER'S DECLARATION, CONTINUED...

SEVEN LAKES DEVELOPMENT, LLC, A WYOMING LIMITED LIABILITY COMPANY, AS OWNER OF "TRACT B" DOES HEREBY ESTABLISH AND ACKNOWLEDGE THIS REPLAT AS THE OFFICIAL MAP AND PLAT OF "SEVEN LAKES REPLAT", PREPARED IN ACCORDANCE WITH ORS CHAPTER 92 AS REVISED AND THE CITY OF PENDLETON AND UMATILLA COUNTY DEVELOPMENT ORDINANCES.

GARY K. JELLUM, MANAGER

ACKNOWLEDGMENT

STATE OF OREGON) SS
COUNTY OF UMATILLA)
THIS INSTRUMENT WAS ACKNOWLEDGED BEFORE ME
THIS 26 DAY OF June 2017.
BY GARY K. JELLUM
Mary Earley
NOTARY PUBLIC FOR THE STATE OF OREGON
MY COMMISSION EXPIRES: February 19, 2018
COMMISSION NUMBER: 925323

RECEIVED BY
Umatilla County Surveyor
Date: 11/30/17
Rec'd By: CT
No.: 17-130-6

WELLS SURVEYING
200 SE HAILEY SUITE 108
P.O. BOX 1696
PENDLETON, OR 97801
PHONE: (541) 276-6362

DATE: 05/17 DR. BY: WRW
CK. BY: WRW NO: 16-1629

PROJECT: SEVEN LAKES REPLAT FINAL

SEVEN LAKES REPLAT
A REPLAT OF LOTS 1, 2, 3 AND
14, 15 AND 16, BLOCK 39, RESERVE ADDITION,
PENDLETON, OREGON

SITUATED IN THE SOUTHWEST QUARTER
OF SECTION 10, TOWNSHIP 2 NORTH,
RANGE 32 EAST, W.M.
CITY OF PENDLETON,
UMATILLA COUNTY, OREGON.