

PARTITION PLAT 2012-19

IN A VACATED PORTION OF BLK. 1, "PENDER FIRST ADDITION" TO THE CITY OF HERMISTON. IN THE SE 1/4 OF THE SW 1/4 OF SEC. 11, T 4 N, R 28 E, W.M, UMATILLA COUNTY, OREGON

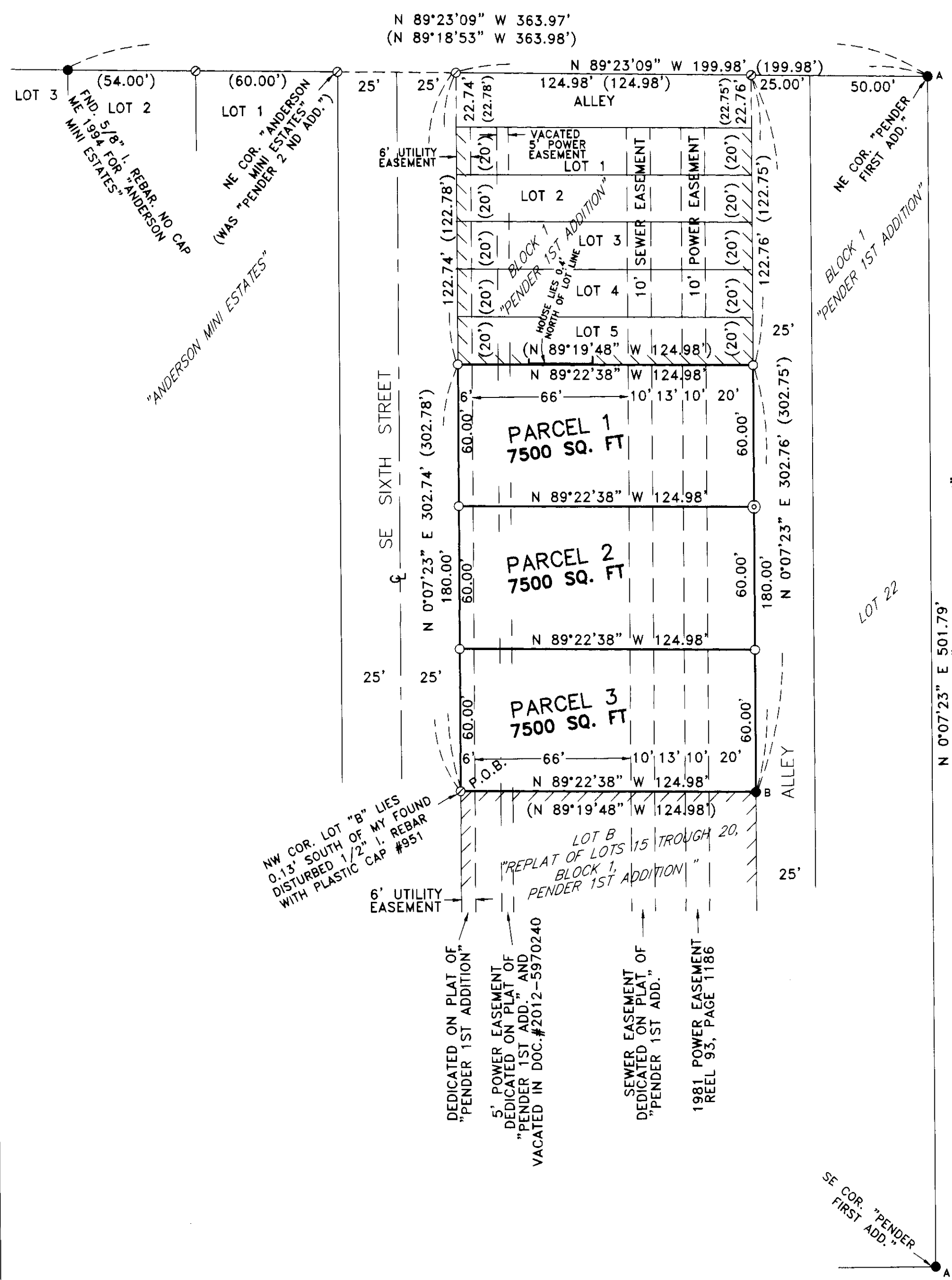

SURVEYORS CERTIFICATE AND NARRATIVE:

I, G. DENNIS EDWARDS, AM A REGISTERED SURVEYOR OF THE STATE OF OREGON, AND HAVE MARKED WITH LEGAL MONUMENTS THE LAND SHOWN ON THIS PLAT. THIS TRACT OF LAND WAS FORMERLY DESCRIBED AS LOTS 6 THROUGH 14, BLOCK 1, "PENDER FIRST ADDITION" TO THE CITY OF HERMISTON. SAID TRACT WAS VACATED IN ORDINANCE #1836 IN 1993 AND IS NOW DESCRIBED IN A DEED TO KEVIN VAN RIPER ON REEL 380, PAGE 269, AND IS DESCRIBED AS FOLLOWS: BEGINNING AT THE NW CORNER OF LOT "B" OF THE "REPLAT OF LOTS 15 THROUGH 20, BLOCK 1, OF PENDER FIRST ADDITION". SAID POINT IS ALSO THE NW CORNER OF WHAT WAS LOT 15 OF SAID BLOCK 1 OF SAID "PENDER FIRST ADDITION" AND RUNNING; THENCE N 0° 07' 23" E 180.00 FEET TO THE SW CORNER OF LOT 5 OF SAID BLOCK 1 OF SAID "PENDER FIRST ADDITION"; THENCE S 89° 22' 38" E 124.98 FEET TO THE SE CORNER OF SAID LOT 5; THENCE S 0° 07' 23" W 180.00 FEET TO THE NE CORNER OF SAID LOT "B"; THENCE N 89° 22' 38" W 124.98 FEET TO THE POINT OF BEGINNING. THIS SURVEY WAS CONDUCTED WITH A TOPCON HIPER + G.P.S. AND THE BEARINGS WERE ROTATED TO MATCH "PENDER FIRST ADDITION".

REGISTERED PROFESSIONAL LAND SURVEYOR
 G. DENNIS EDWARDS
 JULY 16, 1971
 RENEWS 12/31/2013

OWNER'S DECLARATION:

I, THE OWNER OF THE HEREON DESCRIBED LAND, HEREBY DECLARE THAT I HAVE CAUSED THIS PLAT TO BE PREPARED. I ACKNOWLEDGE THE EASEMENTS, ALLEYS, AND STREETS AS SHOWN. I HEREBY DEDICATE THE 6 FOOT UTILITY, THE 10 FOOT SEWER, AND THE 10 FOOT POWER EASEMENTS WHICH RUN NORTH AND SOUTH THROUGH THIS TRACT AS SHOWN.

Kevin W. Van Riper
 KEVIN W. VAN RIPER, OWNER

STATE OF OREGON COUNTY OF UMATILLA }
 BEFORE ME THIS 25th DAY OF October, 2012. APPEARED KEVIN W. VAN RIPER, OWNER AND ACKNOWLEDGED THE FOREGOING DEDICATION.

Virginia J. Holmes
 NOTARY PUBLIC FOR OREGON
 PRINTED NAME Virginia J. Holmes
 COMMISSION NO. 437022
 MY COMMISSION EXPIRES 03-02-2013

- LEGEND:
- FOUND MONUMENTS AS NOTED OR
 - ▲ FOUND 5/8" I. REBAR WITH 2" ALUM. CAP BURNETT, PLAT OF "PENDER 1ST ADDITION"
 - FOUND 1/2" I. REBAR WITH PLASTIC CAP #951, ME REPLAT OF LOTS 15-20, BLOCK 1 OF "PENDER 1ST ADDITION"
 - ⊙ COMPUTED LOCATION
 - SET 5/8"x30" IRON REBAR WITH PLASTIC CAP #951
 - ⊙ SET 5/8"x15" IRON REBAR WITH PLASTIC CAP #951 IN CONCRETE (000) OF RECORD, PLAT OF "PENDER 1ST ADD." OR "ANDERSON MINI EST."

APPROVALS:
 UMATILLA COUNTY SURVEYOR
 APPROVED THIS 25 DAY OF October, 2012
 David H. Kline
 UMATILLA COUNTY SURVEYOR
 CITY OF HERMISTON PLANNING COMMISSION
 APPROVED THIS 22 DAY OF October, 2012
 Margaret Taylor
 CHAIRMAN
 HERMISTON IRRIGATION DISTRICT
 APPROVED THIS 24th DAY OF October, 2012
 Jerry Behr
 MANAGER
 UMATILLA COUNTY TAX COLLECTOR
 TAXES ARE PAID IN FULL
 APPROVED THIS 8 DAY OF November, 2012
 Bettina Erndt
 UMATILLA COUNTY TAX COLLECTOR

STATE OF OREGON, COUNTY OF UMATILLA }
 I certify that this instrument was received and recorded ON November 9, 2012 at 9:00 o'clock Am., in the record of PLATS of said County.
 YEAR NUMBER Slide
 2012 19
 OFFICE OF COUNTY RECORDS
 By: ...STEVE CHURCHILL...Records Officer
 Fees \$ 73.00 No. 2012-5980344

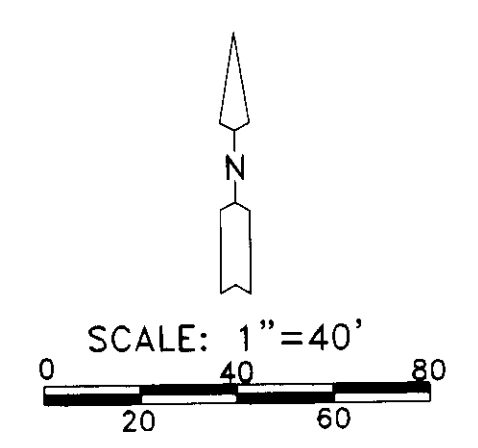

RECEIVED BY
 Umatilla County Surveyor
 Date: 11/16/2012
 Rec'd By: S. Res
 No.: 12-147-B

THIS IS AN EXACT COPY: G. DENNIS EDWARDS

JOB# S1208058
 EDWARDS SURVEYING P.O. BOX 763
 541-567-3336 HERMISTON, OREGON 97838
 DRAWN BY JMC