

PARTITION PLAT NO. 2000-54
 LOCATED IN THE NORTHEAST 1/4 OF
 SECTION 15, TOWNSHIP 2 NORTH, RANGE
 32 EAST, W.M., CITY OF PENDLETON,
 UMATILLA COUNTY, OREGON.
 SHEET 1 OF 2

LEGEND

- ⊙ - SET 5/8" BY 30" IRON REBAR WITH 1 1/2" YELLOW PLASTIC CAP MARKED "OR PLS 1106 - WA PLS 17372".
- ⊕ - FOUND 5/8" IRON REBAR WITH 1 1/2" YELLOW PLASTIC CAP MARKED "OR PLS 1106, WA PLS 17372", SURVEY NO. 00-023-C.
- ⊙ - FOUND 5/8" IRON REBAR WITH 1 1/2" YELLOW PLASTIC CAP MARKED "OR PLS 1106, WA PLS 17372", SURVEY NO. 96-088-B OR NO. 94-118-B.
- - MONUMENT FOUND, 5/8" IRON PIN WITH ALUMINUM CAP, FROM SURVEY NO. 82-44-B.
- ⊕ - FOUND "PK" NAIL BY CITY OF PENDLETON, DENOTING TUTUILLA ROAD CENTERLINE ALIGNMENT.
- (XOX) - RECORD DIMENSION FROM SURVEY NO. 82-44-B.
- (XOX)D - RECORD DIMENSION FROM DEED DESCRIPTION.
- <XOX> - RECORD DIMENSION FROM SURVEY NO. 96-088-B OR 94-118-B. (BOTH ARE SAME BEARING BASE).
- - INDICATES ANGLE POINT IN DEED DESCRIPTION BOUNDARY --- NOT SURVEYED OR MONUMENTED.
- ① - SEE "EASEMENT NOTES".

OWNER: CIRCLE DOT RANCHES

LINE TABLE

NO.	BEARING	DISTANCE
L1	S 50°48'59" E	45.40'
L2	N 61°14'31" E	83.61'
L3	N 39°11'01" E	128.20'
L4	(S 64°07' W	73.3')D
L5	(S 54°44' W	156.4')D
L6	(S 65°41' W	74.6')D
L7	(N 64°17'30" W	175.3')D
L8	(N 86°02'30" W	140.7')D
L9	(S 78°13'30" W	114.2')D
L10	(N 71°04'29" E	96.02')D
L11	(S 35°21'01" E	92.78')D
L12	(S 77°27'45" E	61.28')D
L13	(S 64°15'34" E	61.85')D
L14	(N 88°47'46" E	47')D
L15	(S 50°15'02" E	30.64')D
L16	(S 81°21'15" E	159.65')D

NOTE: ALL UNSURVEYED DIMENSIONS SHOULD BE CONSIDERED "MORE OR LESS".

CURVE TABLE

NO.	DELTA	RADIUS	LENGTH	LONG CHORD
C1	20°06'04"	1183.96'	415.37'	N 40°45'57" W 413.24'
C2	1°38'00"	1213.96'	34.60'	N 50°00'08" W 34.60'

PARCEL 2
 33.46 ACRES M/L
 (UNSURVEYED)

① APPROXIMATE LOCATION ONLY

NOTE:
 RECORD DOCUMENT USED FOR OVERALL PROPERTY DESCRIPTION IS "DEED IN LIEU OF FORCLOSURE" RECORDED AT REEL 224, PAGE 1157, DEED RECORDS OF UMATILLA COUNTY, EXCEPTING THEREFROM, THAT LAND SOLD TO JOHN WHITESSELL.

North 1/4 Corner Section 15
 Fd. 2 1/2" brass cap on g.i.p.
 Survey No. 90-50-C.

SEE SURVEY NO. 00-023-C
 OWNER: MRB ENTERPRISES

OWNER: CIRCLE DOT RANCHES

PARCEL 1
 0.96 ACRE M/L

OWNER DELBERT WACHTER

EASEMENT NOTES

- ① - EXISTING 20' RIGHT-OF-WAY EASEMENT GRANTED TO MAUTZ AND TIMMERMAN, RECORDED AT BOOK 332, PAGE 286, DEED RECORDS.
- ② - EXISTING NON-EXCLUSIVE EASEMENT GRANTED TO THE CITY OF PENDLETON, RECORDED AT REEL 164, PAGES 1180, 1190, 1617, AND 1627 DEED RECORDS.

"BLANKET" TYPE EASEMENTS WHICH MAY AFFECT PARCEL 1 AND 2 AS DISCLOSED BY PRELIMINARY TITLE REPORT PREPARED BY PIONEER TITLE COMPANY, 132 S.E. COURT AVENUE, PENDLETON, OREGON, REPORT NO. 64891, DATED AUGUST 22, 2000:

1. EASEMENT FOR POLE LINES AND APPURTENANCES THERETO, GRANTED TO THE PACIFIC TELEPHONE AND TELEGRAPH COMPANY, RECORDED AT BOOK 160, PAGE 473, DEED RECORDS. AFFECTS THE W 1/2 OF THE NE 1/4 SECTION 15.
2. RIGHT-OF-WAY EASEMENT GRANTED TO PACIFIC POWER AND LIGHT COMPANY, RECORDED AT BOOK 185, PAGE 259, DEED RECORDS. AFFECTS E 1/2 SECTION 15.
3. RIGHT-OF-WAY EASEMENT GRANTED TO PACIFIC POWER AND LIGHT COMPANY, RECORDED AT BOOK 201 PAGE 318, DEED RECORDS. AFFECTS NE 1/4 SECTION 15.
4. RIGHT-OF-WAY EASEMENT GRANTED TO EASTERN OREGON ELECTRIC COOPERATIVE ASSOCIATION, RECORDED AT BOOK 260, PAGE 520, DEED RECORDS. AFFECTS SECTION 15.
5. RIGHT-OF-WAY EASEMENT GRANTED TO EASTERN OREGON ELECTRIC COOPERATIVE ASSOCIATION, RECORDED AT BOOK 260, PAGE 520. AFFECTS SECTION 15.
6. RIGHT-OF-WAY EASEMENT GRANTED TO EASTERN OREGON ELECTRIC COOPERATIVE ASSOCIATION, RECORDED AT BOOK 273, PAGE 140. AFFECTS SECTION 15.

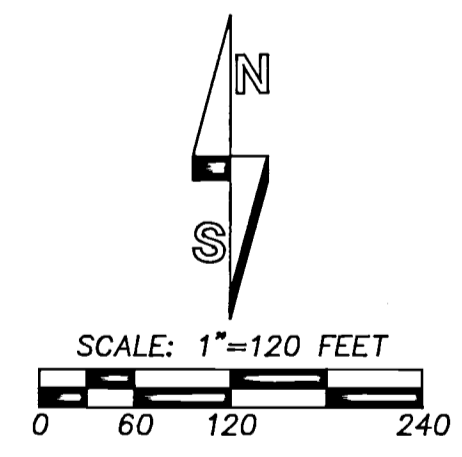

REFERENCE SURVEYS

SEE SURVEY NO. 82-44-B, SURVEY NO. 94-118-B, SURVEY NO. 96-088-B, AND SURVEY NO. 00-023-C.

I CERTIFY THIS IS AN EXACT COPY OF PARTITION PLAT NO. 2000-54
Will R. Wells
 WILLIAM R. WELLS

REGISTERED PROFESSIONAL LAND SURVEYOR

Will R. Wells
 OREGON
 JULY 22, 1977
 WILLIAM R. WELLS
 1106
 RENEWS 06/30/02

WILLIAM R. WELLS, PLS
 357 N.E. HWY. 11
 P.O. BOX 1696
 PENDLETON, OR 97801
 PHONE: (503) 276-6362

DATE: 9/2000 DR. BY: DMT
 CK. BY: WRW NO: 00-724

PROJECT:
 PARTITION PLAT
 ON LANDS OWNED BY
 LINDA SHAFER

LOCATED IN THE NE 1/4 QUARTER OF SECTION 15, T2N., R32E., W.M., UMATILLA COUNTY, OREGON.

RECEIVED BY
 Umatilla County Surveyor
 12-00
 Gued By: *KE*
 No. 00-267-B
 SPIESSPP

PARTITION PLAT 2000-54
LOCATED IN THE NORTHEAST 1/4 OF
SECTION 15, TOWNSHIP 2 NORTH, RANGE
32 EAST, W.M., CITY OF PENDLETON,
UMATILLA COUNTY, OREGON.
SHEET 2 OF 2

OWNER'S DECLARATION

I, LINDA SHAFER, DO HEREBY ACKNOWLEDGE THAT I HAVE CAUSED THIS PARTITION PLAT TO BE PREPARED AND THIS LAND PARTITIONED IN ACCORDANCE WITH ORS CHAPTER 92, AS REVISED, AND THE CITY OF PENDLETON AND UMATILLA COUNTY ORDINANCE.

Linda Shafer
LINDA SHAFER, OWNER

SUBSCRIBED AND SWORN BY ME THIS 16 DAY OF
November 2000.

Dawn M Tubbs
NOTARY PUBLIC FOR THE STATE OF OREGON

MY COMMISSION EXPIRES: 10-14-2004



SURVEYOR'S CERTIFICATE & NARRATIVE

I CERTIFY THAT I HAVE SURVEYED AND MONUMENTED PARCEL 1 OF THIS PARTITION PLAT IN ACCORDANCE WITH ORS CHAPTER 92, AS REVISED, AND CITY OF PENDLETON ORDINANCE. PARCEL 1 IS MONUMENTED AS SHOWN, PARCEL 2 IS UNSURVEYED. THIS SURVEY WAS MADE WITH A 2 PERSON CREW USING A SOKKIA SET 48 FIVE SECOND TOTAL STATION. MONUMENTS WERE ESTABLISHED BY RADIAL METHODS AND VERIFIED BY SEPARATE, INDEPENDENT OBSERVATIONS.

REAL PROPERTY DESCRIPTION

A TRACT OF LAND LOCATED IN THE EAST HALF OF SECTION 15, TOWNSHIP 2 NORTH, RANGE 32, EAST, W.M., AND BEING DESCRIBED AS FOLLOWS:

COMMENCING AT THE NORTH ONE-QUARTER CORNER OF SAID SECTION 15; THENCE SOUTH 20°01'38" EAST A DISTANCE OF 2117.76 FEET TO THE SOUTHEAST CORNER OF THAT TRACT OF LAND DEEDED TO JOHN WHITESELL IN WARRANTY DEED RECORDED AT REEL 290, PAGE 217, DEED RECORDS OF UMATILLA COUNTY, OREGON, SAID POINT BEING LOCATED ON THE EAST RIGHT-OF-WAY LINE OF TUTUILLA ROAD (A.K.A. COUNTY ROAD NO. 915) AND BEING THE "INITIAL POINT" FOR THIS DESCRIPTION; THENCE NORTH 39°11'01" EAST A DISTANCE OF 128.20 FEET TO THE NORTHEAST CORNER OF SAID WHITESELL TRACT; THENCE NORTH 61°14'31" EAST A DISTANCE OF 236.57 FEET; THENCE SOUTH 83°54'19" EAST A DISTANCE OF 156.50 FEET; THENCE NORTH 45°15'01" EAST A DISTANCE OF 225.50 FEET; THENCE NORTH 78°12'31" EAST A DISTANCE OF 458.3 FEET, MORE OR LESS; THENCE NORTH 64°07' EAST A DISTANCE OF 73.3 FEET, MORE OR LESS; THENCE NORTH 54°44' EAST A DISTANCE OF 156.4 FEET, MORE OR LESS; THENCE NORTH 65°41' EAST A DISTANCE OF 74.6 FEET, MORE OR LESS; THENCE SOUTH 64°17'30" EAST A DISTANCE OF 175.3 FEET, MORE OR LESS; THENCE SOUTH 86°02'30" EAST A DISTANCE OF 140.7 FEET, MORE OR LESS; THENCE NORTH 78°13'30" EAST A DISTANCE OF 114.2 FEET, MORE OR LESS; THENCE NORTH 51°25' EAST A DISTANCE OF 183.5 FEET, MORE OR LESS; THENCE SOUTH 00°04'30" WEST A DISTANCE OF 1245.7 FEET, MORE OR LESS, TO A POINT ON THE EAST LINE OF SAID SECTION 15; THENCE SOUTH 87°37' WEST A DISTANCE OF 1008.85 FEET, MORE OR LESS, TO A POINT ON THE SOUTH LINE OF THAT TRACT OF LAND AS EXCEPTED IN CONTRACT BETWEEN LESTER SHAFER, ET UX, VENDORS AND CARL SHERWOOD, AS VENDEE, RECORDED IN BOOK 257, PAGE 661, DEED RECORDS; THENCE NORTH 02°23'00" WEST A DISTANCE OF 391.01 FEET, MORE OR LESS; THENCE SOUTH 71°04'29" WEST A DISTANCE OF 96.02 FEET, MORE OR LESS; THENCE NORTH 35°21'01" WEST A DISTANCE OF 92.78 FEET, MORE OR LESS; THENCE NORTH 77°27'45" WEST A DISTANCE OF 61.28 FEET, MORE OR LESS; THENCE NORTH 64°15'34" WEST A DISTANCE OF 61.85 FEET, MORE OR LESS; THENCE SOUTH 88°47'48" WEST A DISTANCE OF 47 FEET, MORE OR LESS; THENCE NORTH 50°15'02" WEST A DISTANCE OF 30.64 FEET, MORE OR LESS; THENCE NORTH 81°21'15" WEST A DISTANCE OF 159.65 FEET, MORE OR LESS; THENCE SOUTH 78°55'29" WEST A DISTANCE OF 237 FEET, MORE OR LESS, TO A POINT ON THE NORTH RIGHT-OF-WAY LINE OF TUTUILLA ROAD; THENCE ALONG THE NORTH RIGHT-OF-WAY LINE OF TUTUILLA ROAD, ON THE ARC OF A 1213.96 FOOT RADIUS CURVE TO THE LEFT A DISTANCE OF 107 FEET, MORE OR LESS, TO THE MOST SOUTHERLY CORNER OF PROPOSED PARCEL 1; THENCE CONTINUING ALONG THE NORTH RIGHT-OF-WAY LINE OF TUTUILLA CREEK ROAD, ON THE ARC OF A 1213.96 FOOT RADIUS CURVE TO THE LEFT A DISTANCE OF 34.60 FEET, (LONG CHORD BEARS NORTH 50°00'08" WEST A DISTANCE OF 34.60 FEET) TO POINT OF TANGENCY; THENCE NORTH 50°48'59" WEST, CONTINUING ALONG SAID RIGHT-OF-WAY LINE A DISTANCE OF 45.40 FEET TO THE "INITIAL POINT".

William R. Wells
WILLIAM R. WELLS, PLS 1106



William R. Wells
OREGON
JULY 22, 1977
WILLIAM R. WELLS
1106
RENEWS 6/30/02

I CERTIFY THIS IS AN EXACT COPY OF PARTITION PLAT
NO. 2000-54
William R. Wells
WILLIAM R. WELLS, PLS

APPROVALS

EXAMINED AND APPROVED THIS
13th DAY OF December, 2000.

LAND PARTITION APPROVAL NO. MP00-04
Roupenal Alullin
CITY OF PENDLETON PLANNING DIRECTOR

EXAMINED AND APPROVED THIS
13th DAY OF DEC, 2000.
Donald J. Odom
PENDLETON CITY SURVEYOR

EXAMINED AND APPROVED THIS
17 DAY OF November, 2000.
David H. Kelly
UMATILLA COUNTY SURVEYOR

TAXES ARE PAID IN FULL THIS
22nd DAY OF December, 2000.
Chandra Schultz
UMATILLA COUNTY TAX COLLECTOR

RECORDING INFORMATION:
OFFICE OF COUNTY RECORDS

STATE OF OREGON, }
COUNTY OF UMATILLA }
I certify that this instrument was received and recorded
ON December 22, 2000
at 10:45 o'clock Am., in the record of
PLATS of said County.
YEAR 2000 PAGE 54 Slide
OFFICE OF COUNTY RECORDS
By: JEAN HEMPHILL Records Officer
Fees \$ 50.00 No. 2000-3800375

WILLIAM R. WELLS, PLS 357 N.E. HWY. 11 P.O. BOX 1696 PENDLETON, OR 97801 PHONE: (503) 276-6362		PROJECT: PARTITION PLAT ON LANDS OWNED BY LINDA SHAFER
DATE: 9/2000	DR. BY: DMT	LOCATED IN THE NE 1/4 QUARTER OF SECTION 15, T2N., R32E., W.M., UMATILLA COUNTY, OREGON.
CK. BY: WRW	NO: 00-724	

RECEIVED BY
Umatilla County Surveyor
Date 12-00
Rec'd By KK
No. 00-267-B SPIESSP2